

THIS DRAWING IS UNPUBLISHED. RELEASED FOR PUBLICATION  
 © COPYRIGHT - By - ALL RIGHTS RESERVED.

LOC	DIST	REVISIONS					
FT	0	P	LTR	DESCRIPTION	DATE	DWN	APVD
		AA6		REVISED PER ECO-14-002476	20FEB2014	NK	MZ

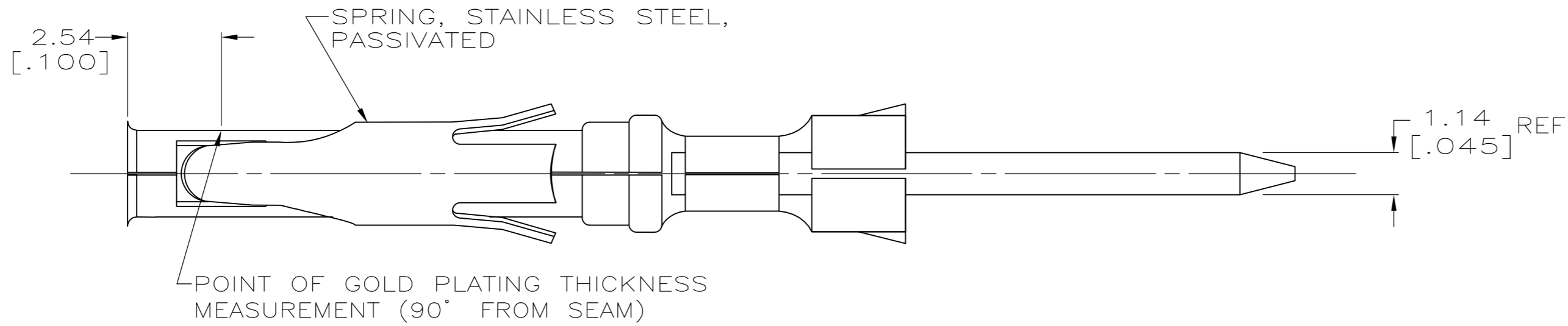

1.689±0.051 DIA  
 [.0665±.0020]

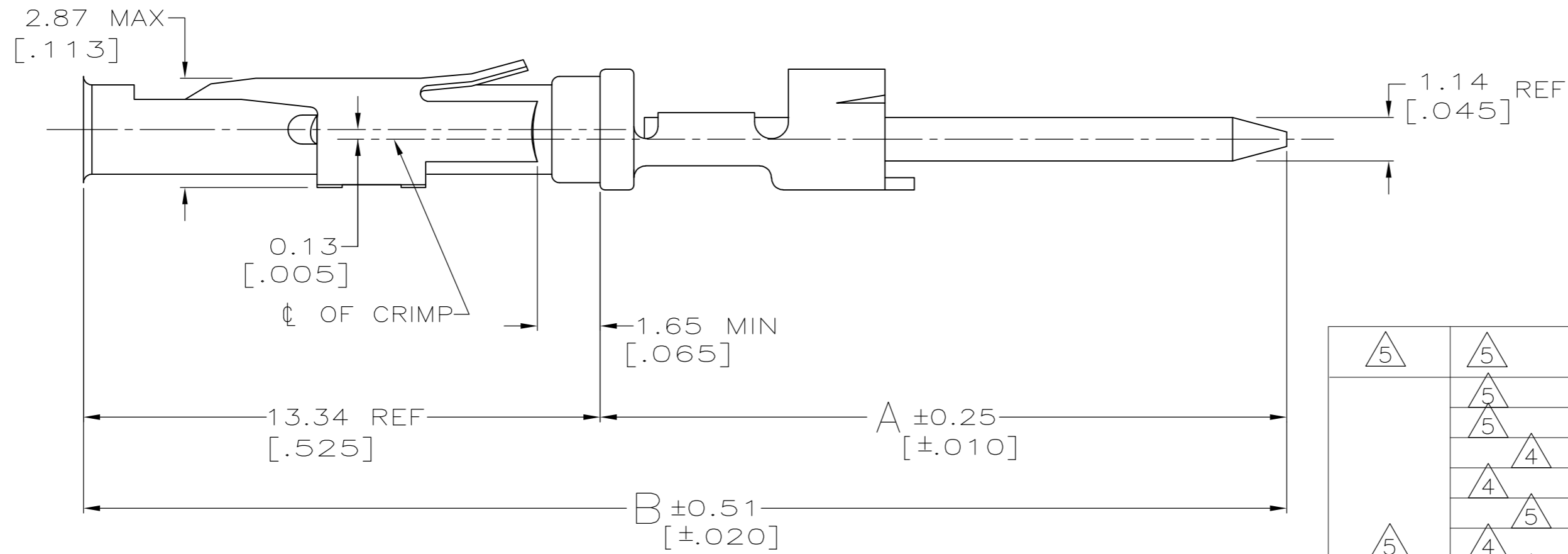

- 1 GOLD PLATING NEED NOT APPEAR ON INSULATION SUPPORT STABILIZER.
- 2 2.54um [.000100] MIN TIN-LEAD PER 112-26-1 OVER 1.27um [.000050] MIN NICKEL PER 112-25-2.
- 3 2.54um [.000100] MIN TIN-LEAD OVER 1.27um [.000050] MIN NICKEL.
- 4 0.76um [.000030] MIN GOLD PER MIL-G-45204 ON MATING END FOR A LENGTH OF 5.08 [.200] MIN WITH A UNIFORM GRADIENT TO 0.25um [.000010] MIN GOLD PER MIL-G-45204 ON THE REMAINDER OVER 0.76um [.000030] MIN NICKEL PER QQ-N-290.
- 5 2.54um [.000100] MIN TIN OVER 1.27um [.000050] MIN NICKEL.
- 6 OBSOLETE PARTS: OBSOLETE CIS STREAMLINING PER D.RENAUD/D.SINISI
- 7 PRELIMINARY PART

FINISH (POST)	FINISH (BODY)	NO OF TERM	A	B	PART NUMBER
5	5	SPECIAL	23.50 [.925]	36.83 [1.450]	2-66473-8
5	5	SPECIAL	36.83 [1.450]	50.17 [1.975]	2-66473-7
	5	2	23.27 [.916]	36.60 [1.441]	2-66473-4
	4	SPECIAL	21.59 [.850]	34.93 [1.375]	2-66473-3
	4	SPECIAL	14.86 [.585]	28.19 [1.110]	2-66473-2
	5	SPECIAL	13.72 [.540]	27.05 [1.065]	2-66473-1
	4	3	29.74 [1.171]	43.08 [1.696]	2-66473-0
	5	3	29.74 [1.171]	43.08 [1.696]	1-66473-8
	4	1	17.81 [.701]	31.14 [1.226]	1-66473-9
	5	3	29.74 [1.171]	43.08 [1.696]	1-66473-8
	4	2	23.27 [.916]	36.60 [1.441]	1-66473-6
3	4	SPECIAL	14.86 [.585]	28.19 [1.110]	1-66473-5
	2	SPECIAL	13.72 [.540]	27.05 [1.065]	1-66473-4
	4	2	23.27 [.916]	36.60 [1.441]	1-66473-1
	4	1	17.81 [.701]	31.14 [1.226]	1-66473-0
	4	3	29.74 [1.171]	43.08 [1.696]	66473-9
	4	1	17.81 [.701]	31.14 [1.226]	66473-7
	2	3	29.74 [1.171]	43.08 [1.696]	66473-3
2	1	17.81 [.701]	31.14 [1.226]	66473-1	

SUPERCEDED BY 1776003-2

THIS DRAWING IS A CONTROLLED DOCUMENT. DWN D. HARDY 05/02/94  
 CHK W.G. LENKER 05/17/94  
 APVD -

DIMENSIONS: mm [INCHES] TOLERANCES UNLESS OTHERWISE SPECIFIED:  
 0 PLC ± -  
 1 PLC ± -  
 2 PLC ± -  
 3 PLC ± 0.13 [.005]  
 4 PLC ± -  
 ANGLES ± -

MATERIAL BRASS PER ASTM B-36 FINISH -

PRODUCT SPEC -  
 APPLICATION SPEC -  
 WEIGHT -

CUSTOMER DRAWING

NAME -  
 SOCKET CONTACT, CRIMPED  
 1.57 [.062] DIA, 1.14 [.045] x  
 1.14 [.045] POST (W.W.)

SIZE A2 CAGE CODE 00779 DRAWING NO C-66473 RESTRICTED TO -  
 SCALE 8:1 SHEET 1 OF 1 REV AA6